

1008 Bronze Ball Valve (Screwed)

Salient Features

- Screwed Female Ends to IS 554 / BS 21 / ISO 7.
- Full Bore, Two Piece Design.
- Quarter Turn, Lever Operated.
- Provided with Stainless Steel Ball.
- Premium Quality PTFE Gland Packing and Seating.

Test Pressure (Hydrostatic) :
Shell : 25 kg/cm²g (350 psig)
Seat : 16 kg/cm²g (225 psig)
Maximum Working Temperature : 220°C

Suitable For

Water, Oil



Materials

P.No.	Name of Part	Material of Construction	Specification	Quantity
1	Body	Bronze	IS 318 GR. LTB 2	1
2	Bonnet	Bronze / Forged Brass	IS 318 GR. LTB 2 / IS 6912 Gr. FLB	1
3	Ball	Stainless Steel	ASTM A276 Type 304 / ASTM A351 Gr. CF8	1
4	Body Seat Ring	PTFE	BS EN 12086 - 1	2
5	Thrust Washer	PTFE	BS EN 12086 - 1	1
6	Gland Packing	PTFE	BS EN 12086 - 1	-
7	Stem	Stainless Steel	ASTM A276 Type 410	1
8	Gland	Forged Brass	IS 6912 Gr. FLB	1
9	Lever	Mild Steel	- - -	1
10	Nut	Carbon Steel	- - -	1

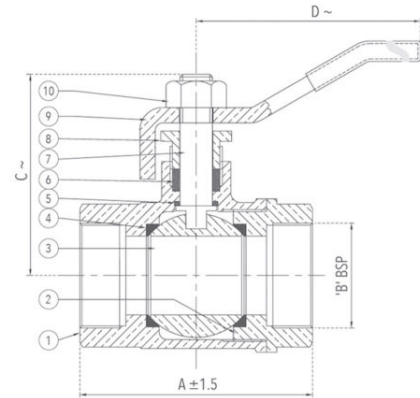

Sizes / Dimensions

Size (Inches)	Size (mm)	A ±1.5	B	C ~	D ~
1/2	15	60	1/2"	44	105
3/4	20	65	3/4"	48	123
1	25	73	1"	58	123
1 1/4	32	91	1 1/4"	73	148
1 1/2	40	91	1 1/2"	80	153
2	50	117	2"	85	213
2 1/2	65	135	2 1/2"	110	245
3	80	162	3"	116	330
4	100	201	4"	139	330

1008A Bronze Ball Valve E-Model (Screwed)

Salient Features

- Screwed Female Ends to IS 554 / BS 21 / ISO 7.
- Full Bore, Two Piece Design.
- Quarter Turn, Lever Operated.
- Provided with Stainless Steel Ball.
- Premium Quality PTFE Gland Packing and Seating.

Test Pressure (Hydrostatic) :
Shell : 20 kg/cm²g (285 psig)
Seat : 13.5 kg/cm²g (192 psig)
Maximum Working Temperature : 220°C

Suitable For

Water, Oil



Materials

P.No.	Name of Part	Material of Construction	Specification	Quantity
1	Body	Bronze	IS 318 Gr. LTB 2	1
2	Bonnet	Bronze / Forged Brass	IS 318 Gr. LTB 2 / IS 6912 Gr. FLB	1
3	Ball	Stainless Steel	ASTM A276 Type 304 / ASTM A351 Gr. CF8	1
4	Body Seat Ring	PTFE	BSEN 12086 - 1	2
5	Thrust Washer	PTFE	BSEN 12086 - 1	1
6	Gland Packing	PTFE	BSEN 12086 - 1	-
7	Stem	Stainless Steel	ASTM A276 Type 410	1
8	Gland	Forged Brass	IS 6912 Gr. FLB	1
9	Lever	Mild Steel	---	1
10	Nut	Carbon Steel	---	1

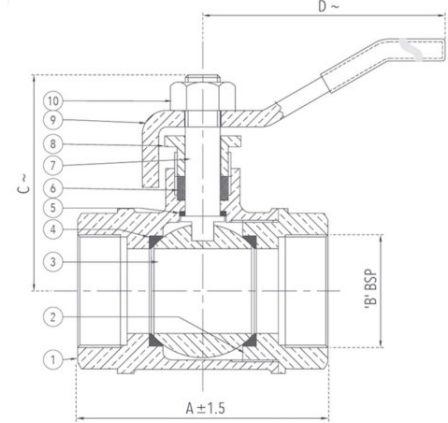

Sizes / Dimensions

Size (Inches)	Size (mm)	A ±1.5	B	C ~	D ~
1/2	15	50	1/2"	36	105
3/4	20	58	3/4"	44	123
1	25	63	1"	53	123
1 1/4	32	73	1 1/4"	65	148
1 1/2	40	85	1 1/2"	72	180
2	50	102	2"	79	220

1008B Forged Brass Ball Valve (Screwed)

Salient Features

- Screwed Female Ends to IS 554 / BS 21 / ISO 7.
- Full Bore, Two Piece Design.
- Quarter Turn, Lever Operated.
- Provided with Forged Brass Hard Chrome Plated Ball.
- Premium Quality PTFE Gland Packing and Seating.
- Chrome Finish.

Test Pressure (Hydrostatic) :
Shell : 25 kg/cm²g (350 psig)
Seat : 16 kg/cm²g (225 psig)
Maximum Working Temperature : 220°C

Suitable For

Water, Oil



Materials

P.No.	Name of Part	Material of Construction	Specification	Quantity
1	Body	Forged Brass	IS 6912 Gr. FLB	1
2	Bonnet	Forged Brass	IS 6912 Gr. FLB	1
3	Ball	Forged Brass (Hard Chrome Plated)	IS 6912 Gr. FLB	1
4	Body Seat Ring	PTFE	BS EN 12086 - 1	2
5	Thrust Washer	PTFE	BS EN 12086 - 1	1
6	Gland Packing	PTFE	BS EN 12086 - 1	-
7	Stem	Forged Brass	IS 6912 Gr. FLB	1
8	Gland	Forged Brass	---	1
9	Lever	Aluminium Alloy / Mild Steel	---	1
10	Nut	Brass (Chrome Plated)	---	1

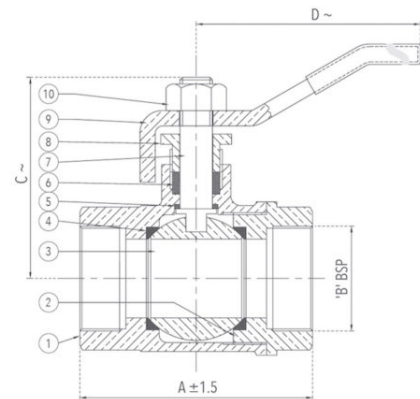

Sizes / Dimensions

Size (Inches)	Size (mm)	A ±1.5	B	C ~	D ~
1/4	8	47	1/4"	37	90
3/8	10	47	3/8"	37	90
1/2	15	50	1/2"	40	106
3/4	20	58	3/4"	43	132
1	25	67	1"	51	132
1 1/4	32	76	1 1/4"	65	166
1 1/2	40	87	1 1/2"	72	176
2	50	104	2"	80	216
2 1/2	65	139	2 1/2"	102	216
3	80	155	3"	110	280
4	100	177	4"	124	280

1080A Stainless Steel (CF8M / S.S 316) Three Piece Design Ball Valve, Class-150 (Screwed)

Salient Features

- Design Standard BS EN ISO 17292 (BS 5351).
- Screwed Female Ends to BSPT / NPT / Socket Weld.
- Reduced Bore, Three Piece Design.
- Superb in Quality and Performance.

Test Pressure (Hydrostatic) :

Shell : 31 kg/cm²g (440 psig)

Maximum Working Pressure : 21 kg/cm²g (300 psig)

Seat (Pneumatic) : 7kg/cm²g (100 psig)

Maximum Working Temperature : 220°C

Suitable For

Steam, Water, Oil, Air, Gases



Materials

P.No.	Name of Part	Material of Construction	Specification	Qty.
1	Body	Stainless Steel	ASTM A 351 Gr. CF8M	1
2	Ball	Stainless Steel	ASTM A276 Type 316 / ASTM A 351 Gr. CF8M	1
3	Thrust Washer	PTFE 35% Carbon Filled	BS EN 12086 - 1	1
4	Stem	Stainless Steel	ASTM A276 Type 316	1
5	Packing Ring	PTFE 35% Carbon Filled	BS EN 12086 - 1	2
6	Gland	Stainless Steel	ASTM A276 Type 316	1
7	Cup Washer	Stainless Steel	ASTM A276 Type 316	2
8	Nut	H.T. Steel	ASTM A 194 Gr. 2H	2
9	Spring Washer	Spring Steel / Stainless Steel	EN 47 Gr. B / Type 316	1
10	Lever	Carbon Steel	---	1
11	Body Seat Ring	PTFE	BSEN 12086 - 1	2
12	Gasket	PTFE	BS EN 12086 - 1	2
13	Spring Washer	Spring Steel / Stainless Steel	EN 47 Gr. B / Type 316	8
14	Studs	Alloy Steel	ASTM A 193 Gr. B7	4
15	Nuts	H.T Steel	ASTM A 194 Gr. 2H	8
16	End Connector	Stainless Steel	ASTM A 351 Gr. CF8M	2

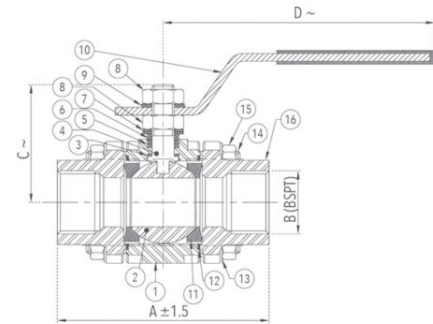

Sizes / Dimensions

Size (Inches)	Size (mm)	A ±1.5	B	C ~	D ~
1/2	15	69	1/2"	38	112
3/4	20	73	3/4"	40	125
1	25	95	1"	57	168
1 1/4	32	105	1 1/4"	65	168
1 1/2	40	115	1 1/2"	75	177
2	50	128	2"	75	220

1080B Stainless Steel (CF8M / S.S 316) Three Piece Design Ball Valve, Class-150 (Flanged)

Salient Features

- Design Standard BS EN ISO 17292 (BS 5351).
- Flanged Ends to ASME B B16.5 Class - 150 (Drilled).
- Three Piece Design.
- Superb in Quality and Performance.

Test Pressure (Hydrostatic) :

Shell : 31 kg/cm²g (440 psig)

Maximum Working Pressure : 21 kg/cm²g (300 psig)

Seat (Pneumatic) : 7 kg/cm²g (100 psig)

Maximum Working Temperature : 220°C

Suitable For

Steam, Water, Oil, Air, Gases



Materials

P.No.	Name of Part	Material of Construction	Specification	Qty.
1	Body	Stainless Steel	ASTM A 351 Gr. CF8M	1
2	Ball	Stainless Steel	ASTM A 276 Type 316 / ASTM A 351 Gr. CF8M	1
3	Thrust Washer	PTFE 35% Carbon Filled	BS EN 12086 - 1	1
4	Stem	Stainless Steel	ASTM A 276 Type 316	1
5	Packing Ring	PTFE 35% Carbon Filled	BS EN 12086 - 1	2
6	Gland	Stainless Steel	ASTM A 276 Type 316	1
7	Cup Washer	Stainless Steel	AISI A276 Type 316	2
8	Nut	H.T. Steel	ASTM A 194 Gr. 2H	2
9	Spring Washer	Spring Steel / Stainless Steel	EN 47 Gr. B / Type 316	1
10	Lever	Carbon Steel	---	1
11	Body Seat Ring	PTFE	BS EN 12086 - 1	2
12	Gasket	PTFE	BS EN 12086 - 1	2
13	Spring Washer	Spring Steel / Stainless Steel	EN 47 Gr. B / Type 316	8
14	Studs	Alloy Steel	ASTM A 193 Gr. B7	4
15	Nuts	H.T Steel	ASTM A 194 Gr. 2H	8
16	End Connector	Stainless Steel	ASTM A 351 Gr. CF8M	2

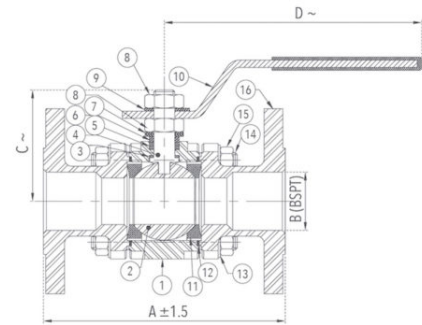

Sizes / Dimensions

Size (Inches)	Size (mm)	A ±1.5	B	C ~	D ~
1/2	15	108	15	38	150
3/4	20	117	20	40	150
1	25	127	25	57	160
1 1/4	32	140	32	65	160
1 1/2	40	165	40	75	202
2	50	178	50	75	202
2 1/2*	65	191	63.5	125	250
3*	80	203	76	137	335
4*	100	229	100	158	335

*Full Bore

1088 Cast Steel Three Piece Design Ball Valve, Class-150 (Screwed)

I.B.R

Salient Features

- Design Standard BS EN ISO 17292 (BS 5351).
- Screwed Female Ends to BSPT / NPT / Socket Weld.
- Reduced Bore, Three Piece Design.
- Superb in Quality and Performance.

Test Pressure (Hydrostatic) :
Shell : 31 kg/cm²g (440psig)
Seat : 21kg/cm²g (300 psig)
Seat (Steam) : 10.55 kg/cm²g (150 psig)
Maximum Working Temperature : 220°C

Suitable For

Steam, Water, Oil



Materials

P.No.	Name of Part	Material of Construction	Specification	Qty.
1	Body	Cast Steel	ASTM A 216 Gr. WCB	1
2	Ball	Stainless Steel	ASTM A 276 Type 304 / ASTM A 351 Gr. CF8	1
3	Thrust Washer	PTFE 35% Carbon Filled	BS EN 12086 - 1	1
4	Stem	Stainless Steel	ASTM A 276 Type 304	1
5	Packing Ring	PTFE 35% Carbon Filled	BS EN 12086 - 1	2
6	Gland	Stainless Steel	ASTM A 276 Type 304	1
7	Cup Washer	Stainless Steel	ASTM A 276 Type 304	2
8	Nut	H.T Steel	ASTM A 194 Gr. 2H	2
9	Spring Washer	Spring Steel / Stainless Steel	EN 47 Gr. B / Type 304	1
10	Lever	Carbon Steel	---	1
11	Body Seat Ring	PTFE	BS EN 12086-1	2
12	Gasket	PTFE	BS EN 12086-1	2
13	Spring Washer	Spring Steel / Stainless Steel	EN 47 Gr. B / Type 304	8
14	Studs	Alloy Steel	ASTM A 193 Gr. B7	4
15	Nuts	H.T Steel	ASTM A 194 Gr. 2H	8
16	End Connector	Cast Steel	ASTM A 216 Gr. WCB	2

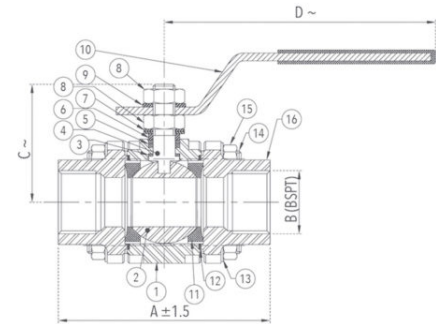

Sizes / Dimensions

Size (Inches)	Size (mm)	A	B	C ~	D ~
1/2	15	69	1/2"	38	112
3/4	20	73	3/4"	40	125
1	25	95	1"	57	168
1 1/4	32	105	1 1/4"	65	168
1 1/2	40	115	1 1/2"	75	177
2	50	128	2"	75	220

1089 Cast Steel Three Piece Design Ball Valve, Class-150 (Flanged) I.B.R.

Salient Features

- Design Standard BS EN ISO 17292 (BS 5351).
- Flanged Ends to ANSI B16.5 Class-150 (Drilled).
- Three Piece Design.
- Superb in Quality and Performance.

Test Pressure (Hydrostatic) :
Shell : 31 kg/cm²g (440 psig)
Seat : 21kg/cm²g (30 psig)
Seat (Steam) : 10.55 kg/cm²g (150 psig)
Maximum Working Temperature : 220°C

Suitable For

Steam, Water, Oil



Materials

P.No.	Name of Part	Material of Construction	Specification	Qty.
1	Body	Cast Steel	ASTM A 216 Gr. WCB	1
2	Ball	Stainless Steel	ASTM A 276 Type 304 / ASTM A 351 Gr. CF8	1
3	Thrust Washer	PTFE 35% Carbon Filled	BS EN 12086-1	1
4	Stem	Stainless Steel	ASTM A 276 Type 304	1
5	Packing Ring	PTFE 35% Carbon Filled	BS EN 12086-1	2
6	Gland	Stainless Steel	ASTM A 276 Type 304	1
7	Cup Washer	Stainless Steel	ASTM A 276 Type 304	2
8	Nut	H.T Steel	ASTM A 194 Gr. 2H	2
9	Spring Washer	Spring Steel / Stainless Steel	EN 47 Gr. B / Type 304	1
10	Lever	Carbon Steel	---	1
11	Body Seat Ring	PTFE	BS EN 12086-1	2
12	Gasket	PTFE	BS EN 12086-1	2
13	Spring Washer	Spring Steel / Stainless Steel	EN 47 Gr. B / Type 304	8
14	Studs	Alloy Steel	ASTM A 193 Gr. B7	4
15	Nuts	H.T Steel	ASTM A 194 Gr. 2H	8
16	End Connector	Cast Steel	ASTM A 216 Gr. WCB	2

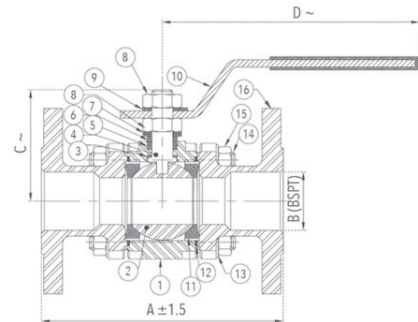

Sizes / Dimensions

Size (Inches)	Size (mm)	A ±1.5	ØB	C ~	D ~
1/2	15	108	15	38	150
3/4	20	117	20	40	150
1	25	127	25	57	160
1 1/4	32	140	32	65	160
1 1/2	40	165	40	75	202
2	50	178	50	75	202
2 1/2*	65	191	63.5	125	250
3*	80	203	76	137	335
4*	100	229	100	158	335

*Full Bore