

1079B Cast Iron Sluice Valve PN 1.6 (Flanged)



Salient Features

- Design Standard IS 14846 PN 1.6.
- Bolted Bonnet, Inside Screw, Non-Rising Stem.
- Rigid and Sturdy design.
- Handwheel Operated.
- Flange Ends as per IS 1538.

Test Pressure (Hydrostatic) :
Shell : 2.4 MPa
Seat : 1.6 MPa
Maximum Working Temperature : 45°C

Suitable For
Water



Materials

P.No.	Name of Part	Material of Construction	Specification	Qty.
1	Body	Cast Iron	IS 210 Gr. FG 200	1
2	Seat Ring	Bronze	IS 318 Gr. LTB 2	4
3	Wedge	Cast Iron	IS 210 Gr. FG 200	1
4	Stem Bush	Bronze	IS 318 Gr. LTB 2	1
5	Gasket	Rubber	IS 638 Type B	1
6	Bonnet	Cast Iron	IS 210 Gr. FG 200	1
7	Stem	Stainless Steel	IS 6603 Gr. 12 Cr. 12	1
8	Gasket	Rubber	IS 638 Type B	1
9	Stuffing Box	Cast Iron	IS 210 Gr. FG 200	1
10	Gland Packing	Hemp & Jute	IS 5414	-
11	Gland Flange	Cast Iron	IS 210 Gr. FG 200	1
12	Handwheel	Cast Iron	IS 210 Gr. FG 200	1
13	Washer	Carbon Steel	---	1
14	Bolt	Carbon Steel	IS 1363 Part 1 Class 4.6	1
15	Bolt & Nut	Carbon Steel	IS 1363 Part 1 Class 4.6 IS 1363 Part 3 Class 4.0	As Reqd.
16	Stud / Bolt	Carbon Steel	IS 1363 Part 1 Class 4.6	2
17	Nut	Carbon Steel	IS 1363 Part 3 Class 4.0	As Reqd.

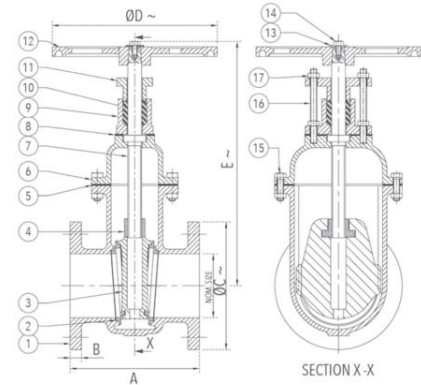

Sizes / Dimensions

Size (Inches)	Size (mm)	A	B	ØC	ØD ±5	E (Max.)
2*	50	178 ±2	16 +2	165 (+1.5/-1.0)	280	365
2 1/2*	65	190 ±2	16 +2	185 (+1.5/-1.0)	280	380
3	80	203 ±2	21 ±3	200 ±4.5	280	425
4	100	229 ±2	22 ±3	220 ±4.5	360	470
5	125	254 ±2	22.5 ±3	250 ±4.5	360	485
6	150	267 ±2	23 ±3	285 (+5.5/-2.5)	360	595
8 [#]	200 [#]	292 ±3	24.5 ±3	340 (+5.5/-2.5)	450	725
10 [#]	250 [#]	330 ±3	26 ±3	395 (+5.5/-2.5)	640	835
12 [#]	300 [#]	356 ±3	27.5 ±3	445 (+5.5/-2.5)	640	910

* Flanges as per IS 14846.

[#] For size 200, 250 and 300 part number 18 is not applicable.

NOTE : Valve is also available with Brass Spindle at a nominal extra cost.

1096 Ductile Iron Sluice Valve PN 1.6 (Flanged)



Salient Features

- Design Standard IS 14846 PN 1.6.
- Bolted Bonnet, Inside Screw, Non-Rising Stem.
- Rigid and Sturdy design.
- Handwheel Operated.
- Flange Ends as per IS 1538.

Test Pressure (Hydrostatic) :
Shell : 2.4 MPa
Seat : 1.6 MPa
Maximum Working Temperature : 45°C

Suitable For
Water

Photo Not Available

Materials

P.No.	Name of Part	Material of Construction	Specification	Qty.
1	Body	Ductile Iron	IS 1865 Gr. SG 500/7	1
2	Body Seat Ring	Bronze	IS 318 Gr. LTB 2	2
3	Wedge Ring	Bronze	IS 318 Gr. LTB 2	2
4	Wedge	Ductile Iron	IS 1865 Gr. SG 500/7	1
5	Stem Bush	Bronze	IS 318 Gr. LTB 2	1
6	Gasket	Rubber	IS 638 Type B	1
7	Bonnet	Ductile Iron	IS 1865 Gr. SG 500/7	1
8	Stem	Stainless Steel	IS 6603 Gr. 12 Cr. 12	1
9	Bolt	Carbon Steel	IS 1363 Part 1 Class 4.6	As Reqd.
10	Nuts	Carbon Steel	IS 1363 Part 3 Class 4.0	As Reqd.
11	Packing	Hemp & Jute	IS 5414	-
12	Gland Flange	Ductile Iron	IS 1865 Gr. SG 500/7	1
13	Handwheel	Ductile Iron	IS 1865 Gr. SG 500/7	1
14	Washer	Carbon Steel	- - -	1
15	Bolt	Carbon Steel	IS 1363 Part 1 Class 4.6	1
16	Nuts	Carbon Steel	IS 1363 Part 3 Class 4.0	2
17	Bolts	Carbon Steel	IS 1363 Part 1 Class 4.6	1
18	Thrust Plate*	Ductile Iron	IS 1865 Gr. SG 500/7	1

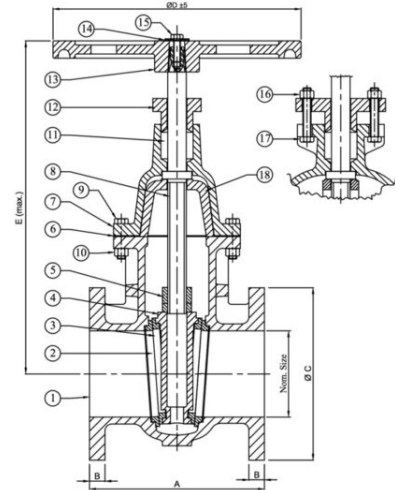

Sizes / Dimensions

Size (Inches)	Size (mm)	A	B	ØC	ØD ±5	E (Max.)
2"	50"	178 ±2	16 +2	165 (+1.5/-1.0)	280	365
2 1/2"	65"	190 ±2	16 +2	185 (+1.5/-1.0)	280	380
3	80	203 ±2	21 ±3	200 ±4.5	280	425
4	100	229 ±2	22 ±3	220 ±4.5	360	470
5	125	254 ±2	22.5 ±3	250 ±4.5	360	485
6	150	267 ±2	23 ±3	285 (+5.5/-2.5)	360	595
8"	200"	292 ±3	24.5 ±3	340 (+5.5/-2.5)	450	725
10"	250"	330 ±3	26 ±3	395 (+5.5/-2.5)	640	835
12"	300"	356 ±3	27.5 ±3	445 (+5.5/-2.5)	640	910

* Flanges as per IS 14846.

* For size 200, 250 and 300 part number 18 is not applicable.