

FLOW CHARACTERISTICS OF BALANCING VALVE

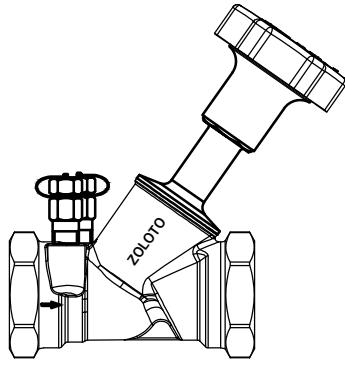

DN 15mm (1/2")



ZOLOTO INDUSTRIES
11th MILESTONE, LAMBRA
NAKODAR ROAD,
JALANDHAR

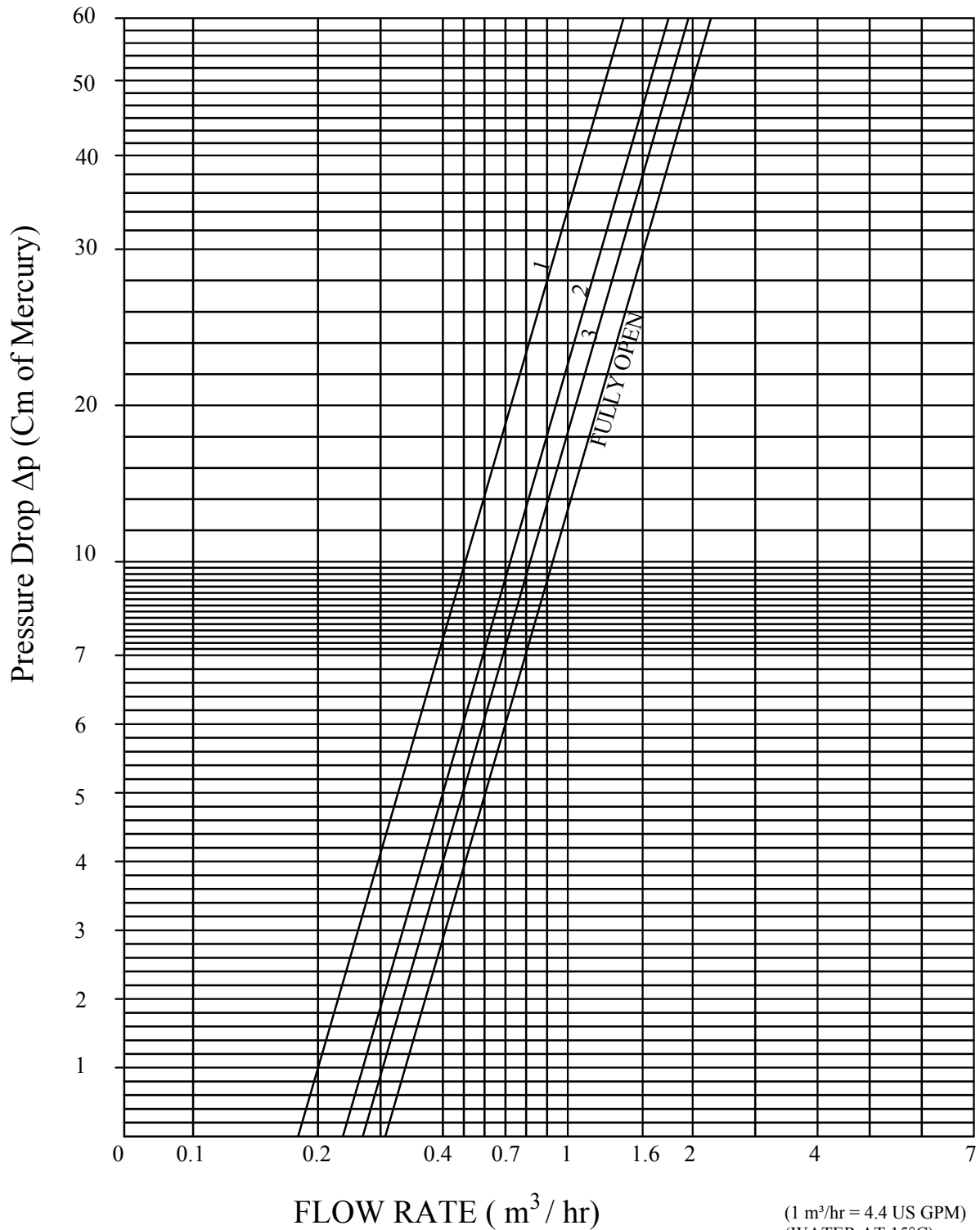

FLOW CHARACTERISTICS OF BALANCING VALVE

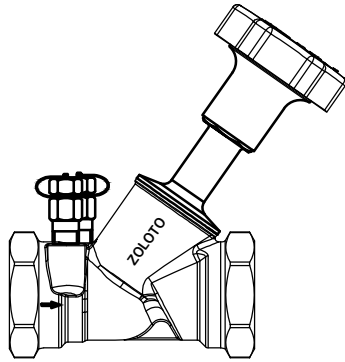

ZOLOTO INDUSTRIES
11th MILESTONE, LAMBRA
NAKODAR ROAD,
JALANDHAR

DN 20mm (3/4")

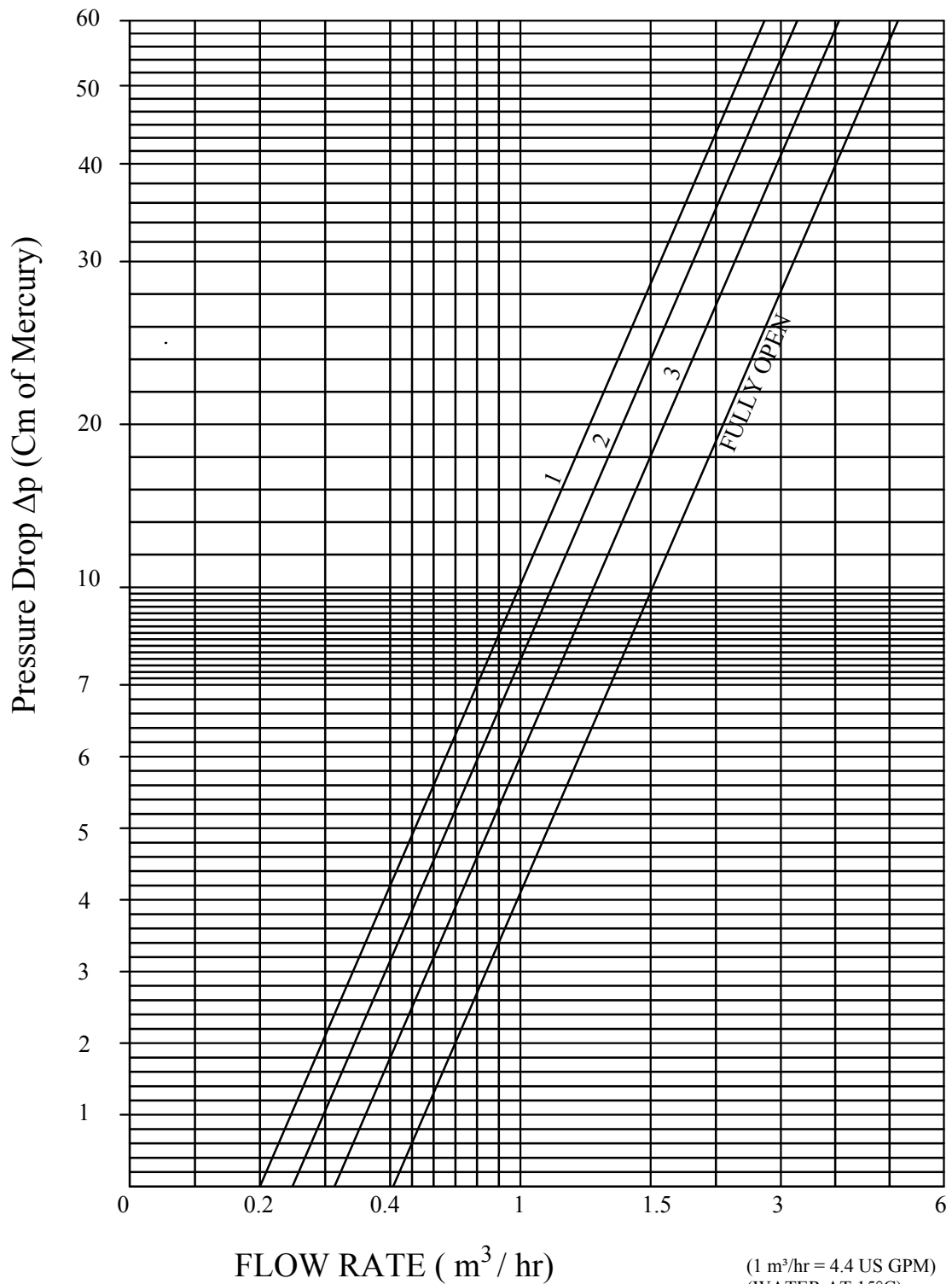

(1 m^3/hr = 4.4 US GPM)
(WATER AT 15°C)

FLOW CHARACTERISTICS OF BALANCING VALVE

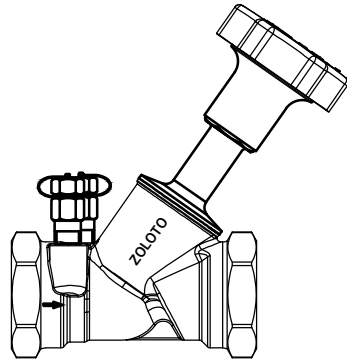

DN 25mm (1")



ZOLOTO INDUSTRIES
11th MILESTONE, LAMBRA
NAKODAR ROAD,
JALANDHAR

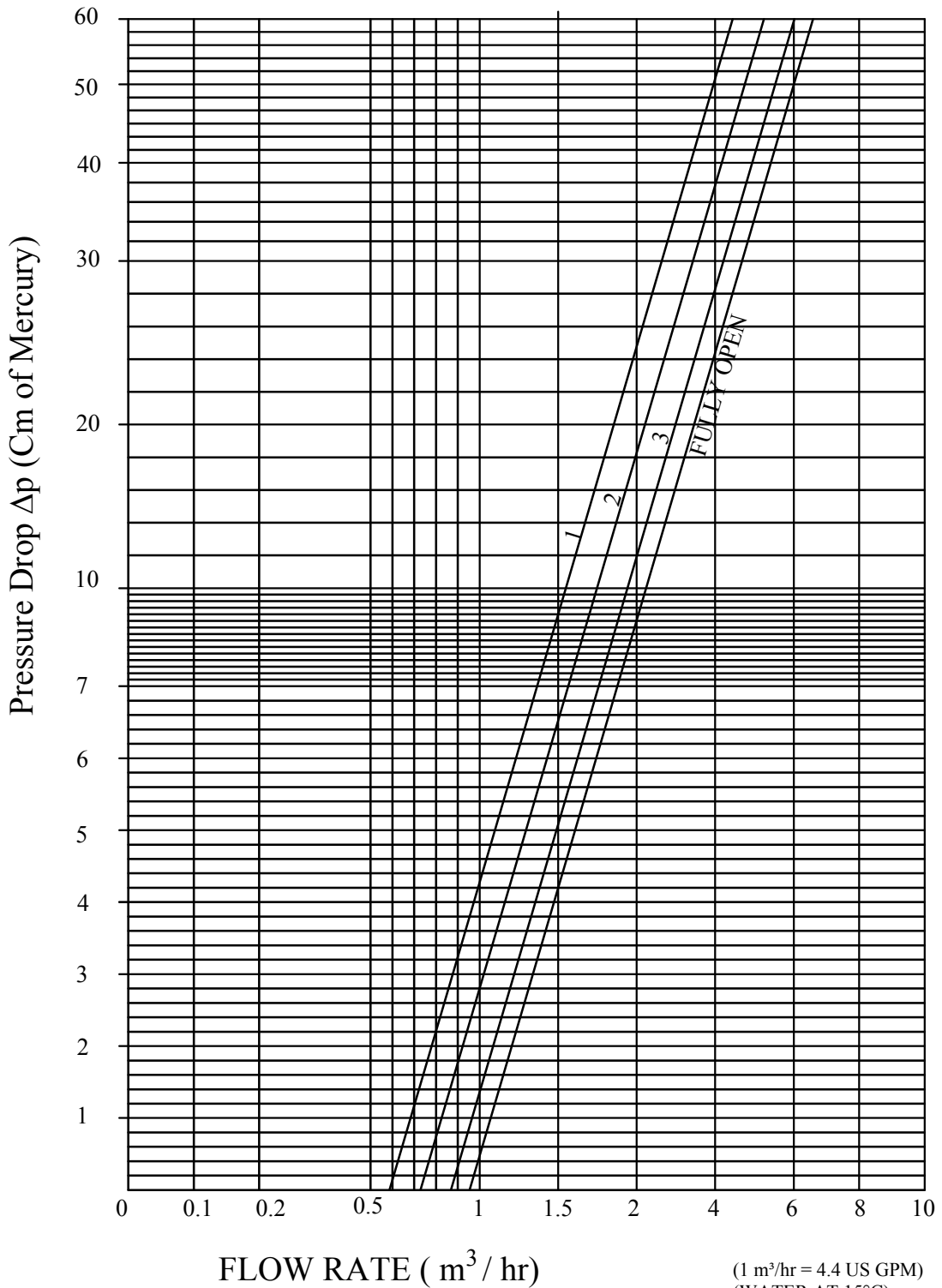

FLOW CHARACTERISTICS OF BALANCING VALVE

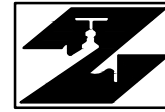
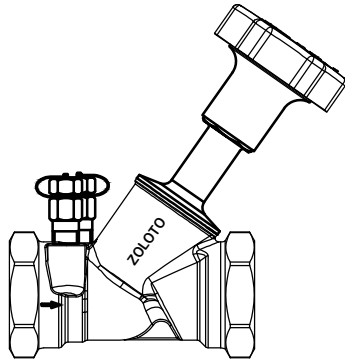

ZOLOTO INDUSTRIES
11th MILESTONE, LAMBRA
NAKODAR ROAD,
JALANDHAR

DN 32mm (1 1/4")

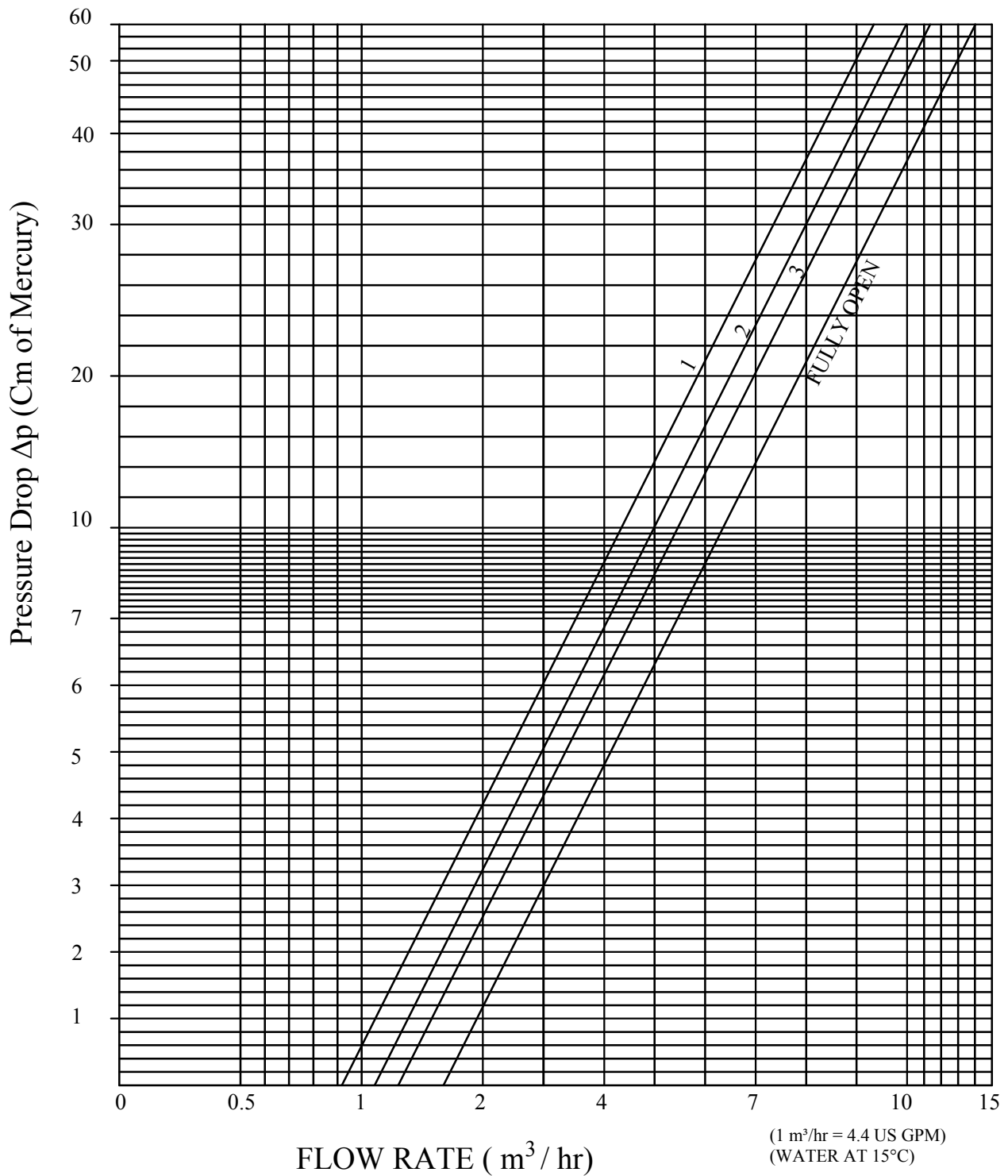

FLOW CHARACTERISTICS OF BALANCING VALVE

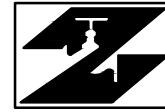
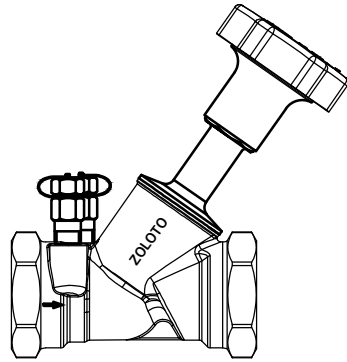

ZOLOTO INDUSTRIES
11th MILESTONE, LAMBRA
NAKODAR ROAD,
JALANDHAR

DN 40mm (1 1/2")

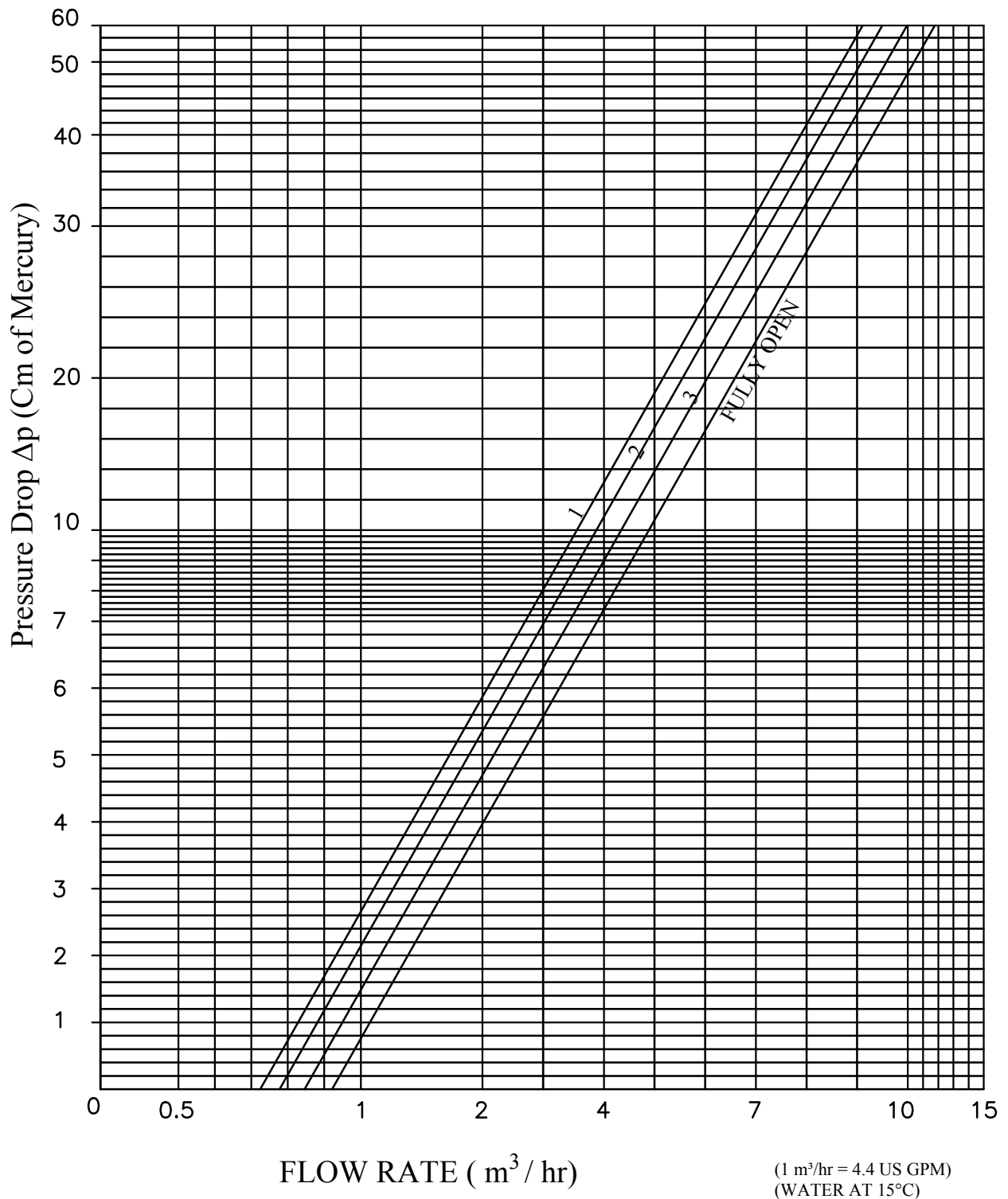

FLOW CHARACTERISTICS OF BALANCING VALVE

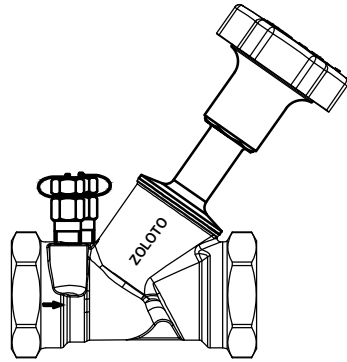

ZOLOTO INDUSTRIES
11th MILESTONE, LAMBRA
NAKODAR ROAD,
JALANDHAR

DN 50mm (2")

